

BOB

OFFSHORE SOLUTIONS

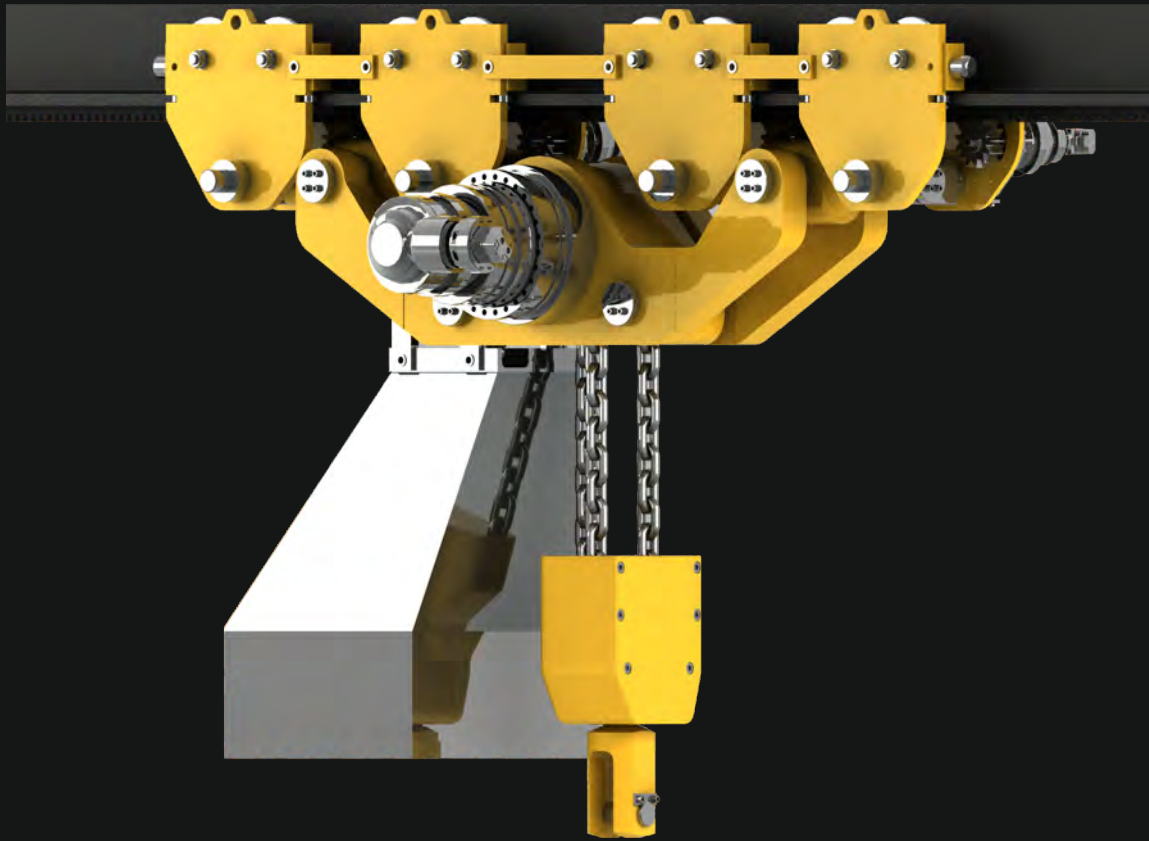

WHAT IS BOB?

BOB is a hydraulic chain hoist designed and manufactured to meet highly demanding requirements of offshore drilling activities.

It's reliable in any applications.

The equipment is API7K, DNV and ABS certified.

WHY SHOULD I CHOOSE BOB?

Purchasing BOB you get:

- Emergency lowering system
- Painting acc. to Norsok M501 - Isocyanate free paint
- Variable speed with full/ no load
- Central lubrication system
- Remote control
- Automatic Multi Disc Brake
- Easy mounted - adjustable trolleys

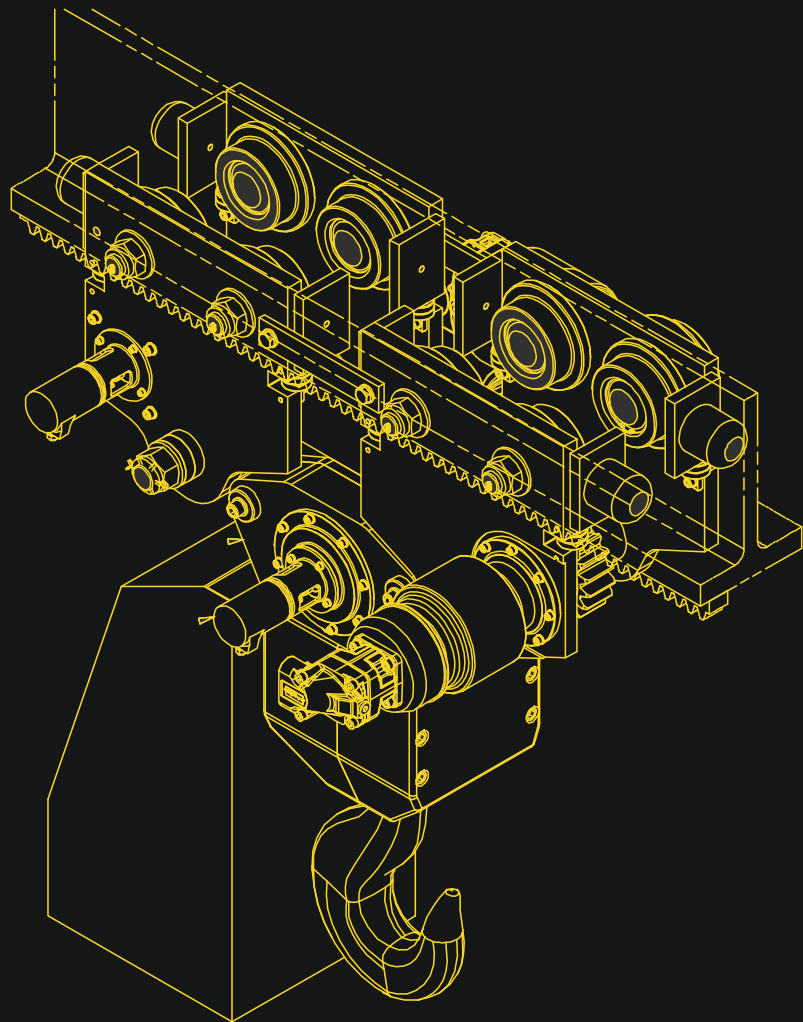

LIFTING CAPACITY :

5	12	18	25	50	60	75	100	200*	TONS
---	----	----	----	----	----	----	-----	------	------

BOB hydraulic chain hoist meets or exceeds the requirements of the following authorities:

- o AMERICAN PETROLUM INSTITUTE (API)
- o DET NORSKE VERITAS (DNV)
- o AMERICAN BUREAU OF SHIPPING (ABS)
- o NORSOK
- o PETROLUM SAFTEY AUTHORITY (PSA)
- o ISDS

WHAT IF ABOVE IS NOT ENOUGH?

If our standard features or hoisting system does not meet your special applications don't worry... customized versions of our equipment is our speciality.

We can also provide an individual official acceptance by corresponding authorities of your choice.

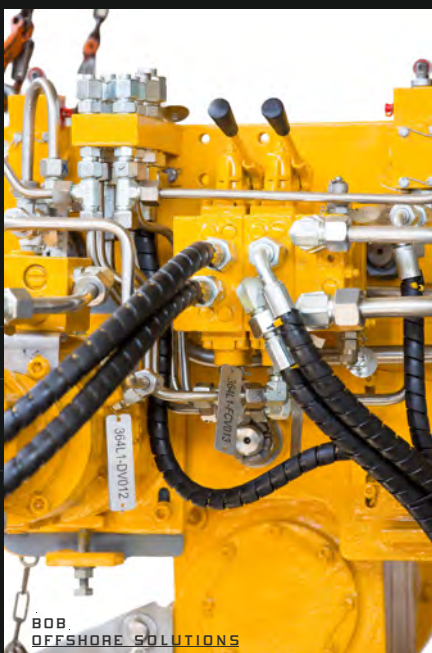

BOB
OFFSHORE SOLUTIONS

BOB HYDRAULIC CHAIN HOIST WAS DESIGNED AND MANUFACTURED IN EU.



BOB OFFSHORE SOLUTIONS

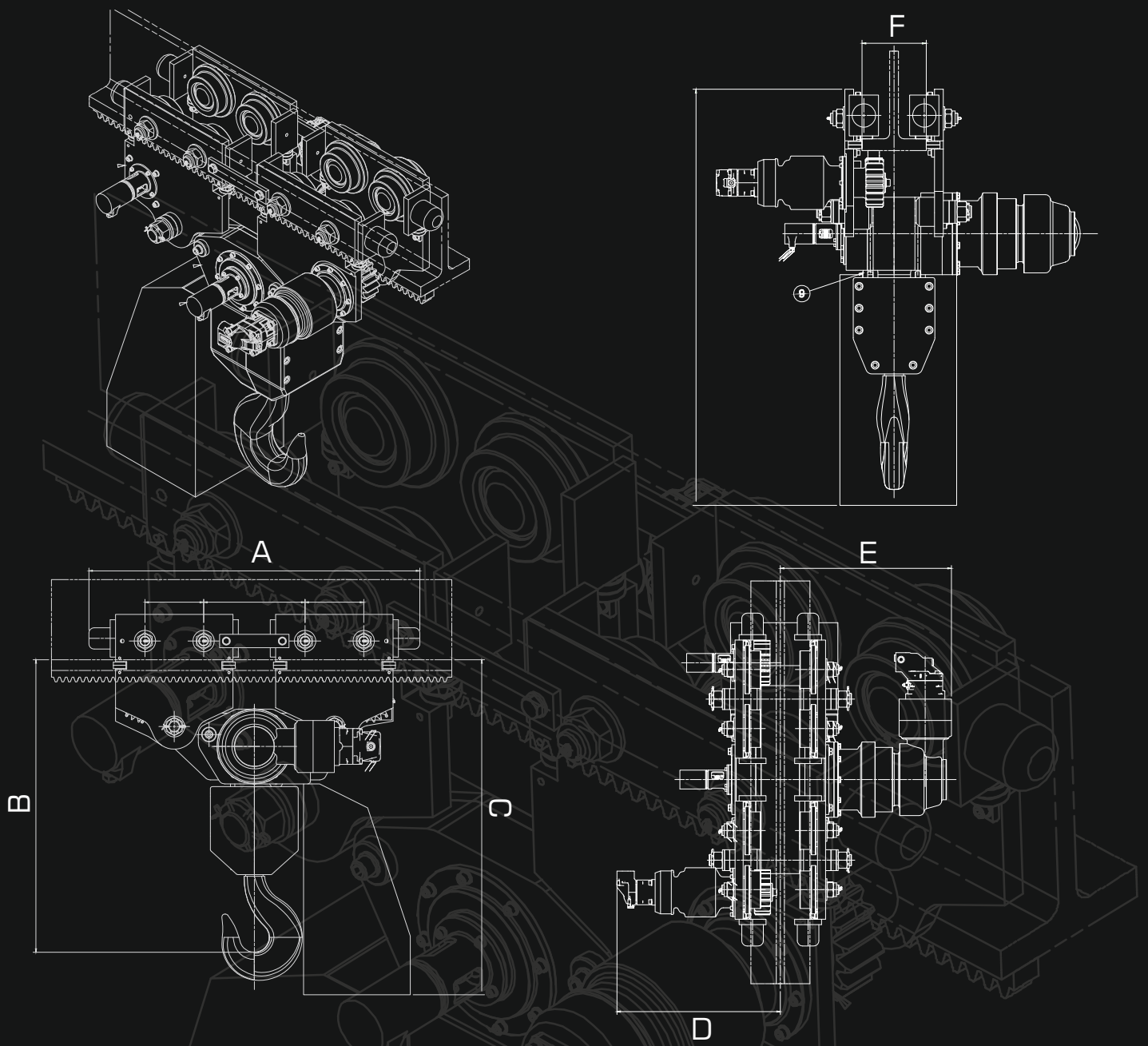

Lifting speed [m/min]**

Dimensions

BOB	SWL	full load	no load	Falls no.	Chain	Weight	A	B	C	D	E	F***
BOB 5	5000	0,5	1,5	4	8x24	484	640	950	1050	599	557	220-300
BOB 12	12000	0,5	1,5	2	16x45	635	640	1209	1210	609	556	220-300
BOB 18	18000	0,5	1,5	3	16x45	1061	1240	1100	1255	609	678	220-300
BOB 25	25000	0,5	1,5	4	16x45	1129	1240	1100	1255	609	638	220-300
BOB 50	50000	0,5	1,5	4	23,5x60	3930	2928	1505	1844	657,5	850	300-350
BOB 60	60000	0,5	1,5	4	23,5x60	3930	2928	1505	1844	657,5	850	300-350
BOB 75	75000	0,5	1,5	3	32x90	8749	3850	1690	2246	684	1205	300-350
BOB 100	100000	0,5	1,5	4	32x90	8886	3850	1690	2246	684	1167	300-350

SWL up to 200 000 kg - tandem solution *
 Lifting speed adjustable to customer requirements **
 Beam size according to customer requirements ***
 Lifting height according to customer requirements ****

BOB alone is great , but 2 BOB's are even better !

Designed to work in a tandem as dedicated
BOP Handling System with capacity up to 200 MT.

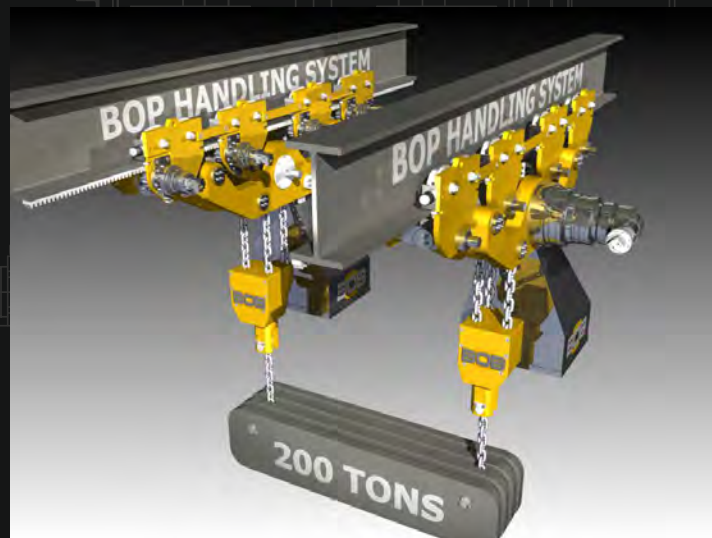
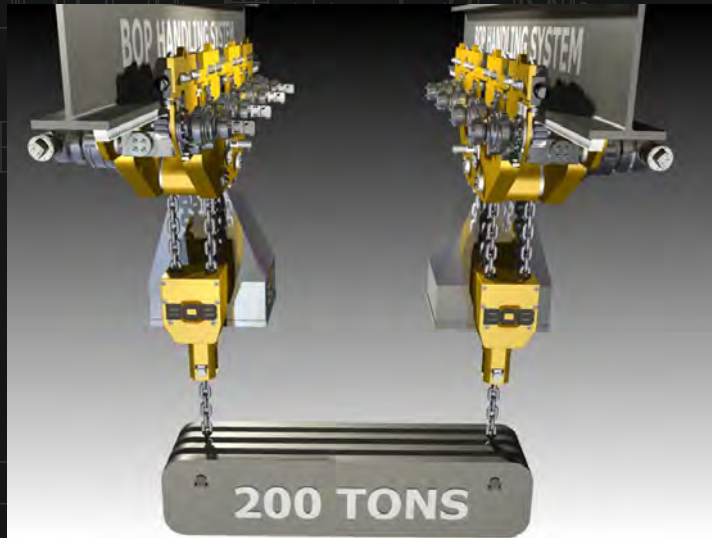

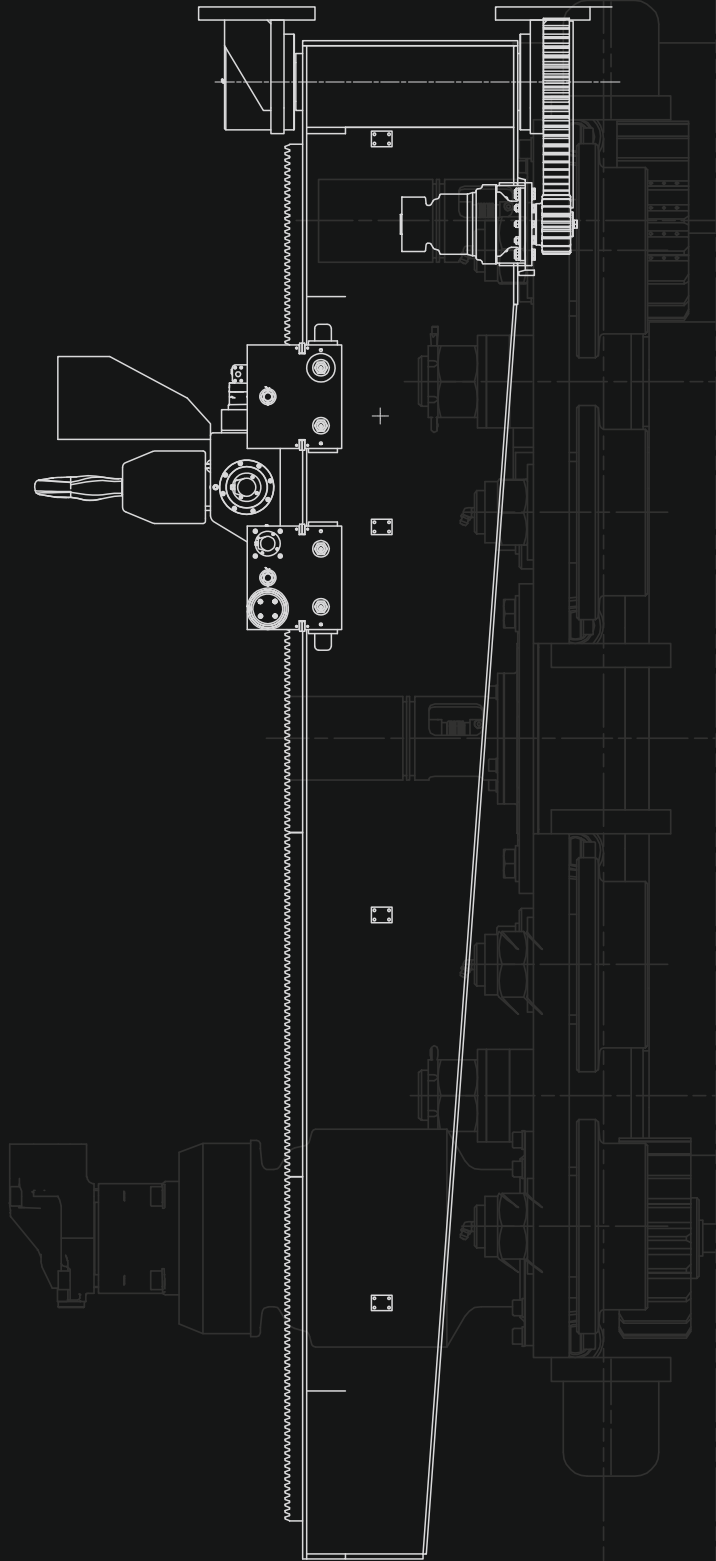

BOB
OFFSHORE SOLUTIONS



BOB
OFFSHORE SOLUTIONS



BOB
OFFSHORE SOLUTIONS

HYDRAULIC CHAIN HOIST



Electric winch Type WEL

- o up to 250t capacity
- o compact design
- o fastening adjustable to existing structures
- o available with power inverter drive
- o wide range of lifting capacity/lenght configuration
- o on request delivered with directional rings





BOB
OFFSHORE SOLUTIONS

www.bob-offshore.no

+47 98 44 18 91

info@bob-offshore.no

4857 Arendal

Postbox 1680 , Stoa

BOP handling system
Service system
Winches / Cranes
Gantry cranes
Hoists